

Best Management Practices for Agricultural Erosion and Sediment Control



TABLE OF CONTENTS

INTRODUCTION.....i
REGULATORY REQUIREMENTS.....ii
CALIFORNIA TIGER SALAMANDER MAP.....iii

CHAPTER ONE

LAYOUT AND SITE DEVELOPMENT.....1
ENVIRONMENTAL CONCERNS..... 1
SITE EVALUATION 1
BEST MANAGEMENT PRACTICES 1, 2
EXAMPLE VINEYARD LAYOUT 3
EXAMPLE VINEYARD LAYOUT NEAR STREAM..... 4

CHAPTER TWO

ROADS 5
ENVIRONMENTAL CONCERNS..... 5
SITE EVALUATION..... 5
BEST MANAGEMENT PRACTICES FOR AGRICULTURAL ROADS..... 6, 7
EXAMPLE OUTSLOPED ROAD 7
EXAMPLE INSLOPED ROAD 7

CHAPTER THREE

COVER CROPS, TILLAGE PRACTICES AND EROSION CONTROL..... 8
ENVIRONMENTAL CONCERNS..... 8
SITE EVALUATION 8
BEST MANAGEMENT PRACTICES 8, 9
COVER CROPS 10
EXAMPLE COVER CROP SEED MIX 11, 12
STRAW MULCH..... 12
EXAMPLE TRACKING IN STRAW MULCH 14
EXAMPLE STRAW BALE SEDIMENT BARRIER 14
STRAW WATTLES..... 15
EXAMPLE STRAW WATTLE..... 16

CHAPTER FOUR

DRAINAGE 17
ENVIRONMENTAL CONCERNS..... 17
SITE EVALUATION 17

BEST MANAGEMENT PRACTICES	18
EXAMPLE OF VINEYARD INLET WITH SEDIMENT TRAP	20
EXAMPLE OF CONCRETE INLET WITH SEDIMENT TRAP	20
EXAMPLE OF ROCK OUTLET FOR STORM DRAINS	21
EXAMPLE OF ROCK OUTLET FOR SWALES	22
EXAMPLE SEDIMENT BASIN.....	23
EXAMPLE AG ROAD WATER BAR.....	24
EXAMPLE TEMPORARY DRAINAGE SWALE	25

CHAPTER FIVE

RIPARIAN ZONES	26
ENVIRONMENTAL CONCERNS:.....	26
SITE EVALUATION	26
BEST MANAGEMENT PRACTICES	27
REQUIRED STREAM SETBACKS	28
LEVEL I PROJECTS AND ALL REPLANTS	28
LEVEL II PROJECTS.....	29
EXAMPLE VINEYARD SETBACK/FILTER STRIP	30
REQUIRED WETLAND AND POND SETBACKS.....	30

Version 1.1 Published February 2010

INTRODUCTION

On December 9, 2008, the Sonoma County Board of Supervisors adopted Ordinance No. 5819, amending the Sonoma County Code and the previously adopted 2007 California Building Code with respect to the regulation of grading, drainage, and vineyard and orchard site development. One of the requirements of this ordinance is compliance with best management practice guidelines. The minimum requirements discussed in this handbook are specific to agricultural practices in Sonoma County for Sonoma County soil types and weather conditions.

The purpose of the Sonoma County Best Management Practices handbook is to provide the minimum requirements to control water quality impacts from accelerated erosion due to agricultural activities in Sonoma County. The intent of this handbook is to show what basic practices are effective in reducing erosion and sedimentation and to show how to install these practices.

It is not the intent of this handbook to provide design criteria for engineered structures. Steeper slopes and projects with grading and drainage components may need structures designed by a licensed engineer.

The process of soil erosion by water involves the detachment of particles from the soil mass, the transportation of the particles by runoff, and the eventual deposition of particles in the form of sediment. Most of the energy responsible for erosion is provided by the impact force of falling raindrops or by the force of surface storm water runoff. Disturbance of soil from farming practices can add to the problem by loosening and pulverizing soil particles, thereby making them more easily moved by rainfall and runoff and by removing the vegetative cover that protects and holds together soil and slows runoff velocity thereby decreasing its capability of transporting soil particles downslope.

Raindrops strike the ground with a velocity of approximately 20 mph. The force of the raindrops breaks apart soil particles, and surface runoff transports the particles downslope. If the soil is not protected from the force of raindrops it will be lost from the agricultural operation and eventually it will be deposited as silt in a creek or waterway where it can have water quality impacts and harm fish habitat.

Drainage features such as pipe with inlets, water bars, swales, and perforated pipe can discharge sufficient water to create a gully, sediment plume, or both, that can extend to a stream channel. These structures are very effective in some situations, provided they have a sediment collection component.

Technical support was provided by Munselle Civil Engineering and Enterra Associates.

Front cover photographs are (clockwise starting from upper left): Rock lined channel designed by Atterbury & Associates, Inc.; olive orchard at Kunde Winery; sediment basin designed by Atterbury & Associates, Inc.; and erosion control featuring cover crop, straw mulch, and straw wattles designed by Edwards Engineering.

REGULATORY REQUIREMENTS

Development of agricultural land for new crop planting or replanting may require permits from various regulatory agencies. The following are some guidelines to help determine if permits would be required and the agencies to contact.

Planting New Vineyard/Orchard or Replanting Existing Vineyard/Orchard

If your project is to plant new vineyard/orchard or replant existing vineyard/orchard, you will need to contact and obtain a permit from the Agricultural Commissioner's Office (707-565-2371).

Removing Trees

Oak trees are protected in certain areas of the county. Check with the Agricultural Commissioner's Office or Permit and Resource Management Department (707-565-1900) to see if a permit is needed. Redwood, fir, and pine trees may not be removed without first contacting the California Department of Forestry (707-963-3601).

Grading and Drainage

If your project involves moving more than 50 cubic yards of soil or stockpiling more than 50 cubic yards of material, you may need a grading permit from the Agricultural Commissioner's Office (707-565-2371). Also, if you are placing fill in the Laguna de Santa Rosa or within the Flood Prone Urban Area (see maps at PRMD) you may need a grading permit. In order to obtain a grading permit you may need to submit engineered plans.

If you are altering surface flow runoff by adding or changing existing drainage swales or installing drainpipe with inlets, you may need drainage review from the Agricultural Commissioner's Office. This review may require you to submit an engineered drainage plan. Re-directing subsurface flow with perforated pipe or french drains may not require drainage review. You must not discharge the pipe directly into a creek or onto a creek bank. Make sure the discharge end of the pipe is protected with rock rip-rap.

Altering a Creek Bed

A creek is defined by the Department of Fish and Game as any drainage way having a defined bed and bank. It doesn't have to be a blue line creek or have water in it all year long to be considered a creek. If it has a bed and bank, it's a creek and therefore under the jurisdiction of the Department of Fish and Game. You may not alter the creek bed or bank without obtaining a Streambed Alteration Permit (1600 permit) from the Department of Fish and Game (707-944-5500). This means you may not discharge a pipe directly into the creek or onto the creek bank, put the creek into a pipe to make your project easier to farm, or put a culvert into or put a bridge over a creek without a 1600 permit.

Wet Areas

Areas that are seasonally or perennially saturated with water can represent unique aquatic plant habitat such as wetland and vernal pools. Many of these areas have endangered species of both plants and animals. A common misconception is that these areas are springs and can be drained with the addition of subsurface drainage. Wet areas are jurisdictional waters of the United States and their development for an agricultural crop may require a permit from the United States Corp of Engineers (415-977-8439). The best advice if you have a wet area is to have it assessed by a biologist before proceeding with site development for your agricultural project.

California Tiger Salamander

On July 22, 2002, the United States Fish and Wildlife Service listed the California tiger salamander as endangered under the federal Endangered Species Act (ESA). The ESA prohibits the "take" of any endangered species (that is the killing or harming of an endangered species, either directly or through adverse modification of habitat). Development of land for agricultural crops is not exempt from ESA. If your project site is located within the potential range of the California tiger salamander as shown on the attached map, you will need to contact the United States Fish and Wildlife Service (916-414-6600) and may have a two year biological study done on site prior to any ground breaking or placing of fill.

Areas in which Sonoma County requires a Biotic Study for California Tiger Salamander

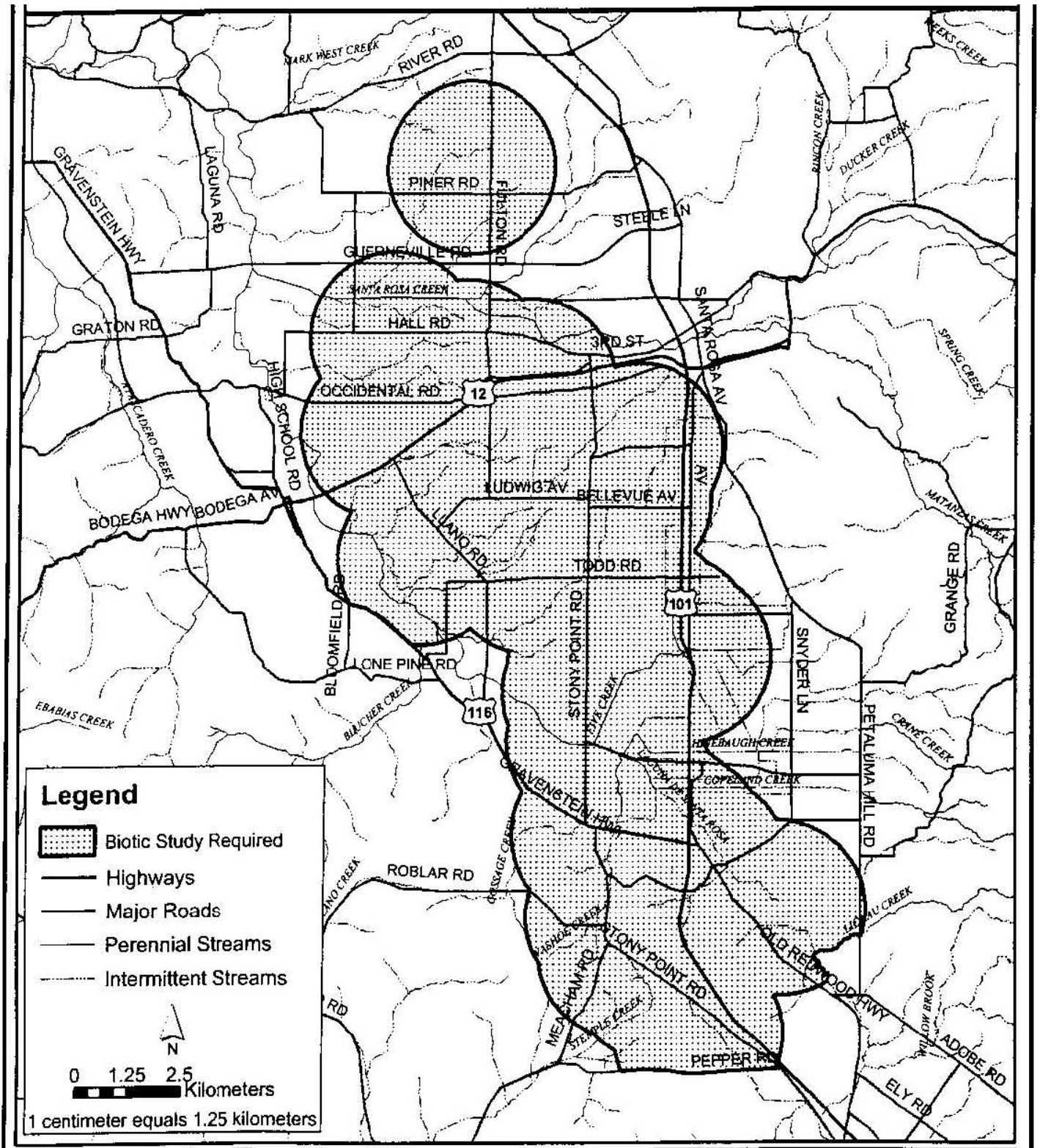

CHAPTER ONE

Layout and Site Development

The layout of a vineyard/orchard can substantially affect the quantity of runoff delivered to a stream. Vineyards/orchards should be planned to take advantage of natural drainage features and maximize infiltration. Steps should be taken to minimize impacts on stream flow. Select varieties of grapes that are appropriate for the soil type, water source and frost conditions.



Environmental Concerns

Steep slopes are more vulnerable to erosion compared to gentle slopes. When fine sediments are eroded from adjacent hillsides, they can settle within the stream channel, fill in pools necessary for rearing, and smother gravels needed for spawning.

Riparian areas provide stability to the natural drainage features of the land and are an important habitat component of streams. Trees provide shade that keeps water cool.

Increased peak flows in a stream increase the likelihood that juvenile salmonids will be flushed downstream away from their rearing habitats

Reduced aquifer recharge reduces summer low flows and may result in a dewatering of streams and salmonid death

Site Evaluation

Examine the property for any signs of instability. Identify soil types, slopes, and types of vegetation, water source, frost prone areas, ponds, wetlands, designated and undesignated streams and riparian zones. Inventory existing roads and drainage improvements.

Best Management Practices

1. In accordance with the County's Grading, Drainage, Vineyard/Orchard Site Development ordinance, for new vineyards/orchards or replanted vineyards/orchards on steep slopes or highly erodible soils, follow plans prepared by a qualified civil engineer.
2. Avoid disturbing any areas with landslides, gullies and slips.
3. Reduce the length of slopes draining to riparian areas using numerous drop inlets with sediment traps, vegetated filter strips, or rolling dips.
4. Incorporate structural erosion control systems to intercept and diffuse water flow and encourage infiltration into vineyard design: Use drop inlets with sediment traps; daylight

underground outlets to vegetated swales; energy dissipaters; infiltration galleries; or sediment basins to prevent excess sediment from entering streams.

5. Plan vineyard/orchard blocks and developed areas supporting the vineyard/orchard to drain to a grassy filter area or a detention/sedimentation pond to remove pollutants.
6. Riparian areas should be avoided if still intact, and if altered, they should be re-vegetated and restored (see Chapter 5 for more details).
7. Consolidate all-weather surfaced access roads, staging areas, and parking away from the riparian zone.
8. Consider the most efficient use of the water for irrigation and frost protection. Avoid planting in frost prone areas (e.g. near trees or buildings) that would require a water source for frost protection. Consider planting in frost prone areas if the area can be protected by wind machines.
9. Avoid planting early budding varieties in frost prone areas that would require sprinkler frost protection (e.g., areas where cold air is trapped by natural topography or vegetation).
10. When planning a new vineyard or a replant, consider dry farming once vines mature and groundwater conditions within the root zone are favorable.
11. Ensure that you have a legal right to your water source.

Example Vineyard Layout

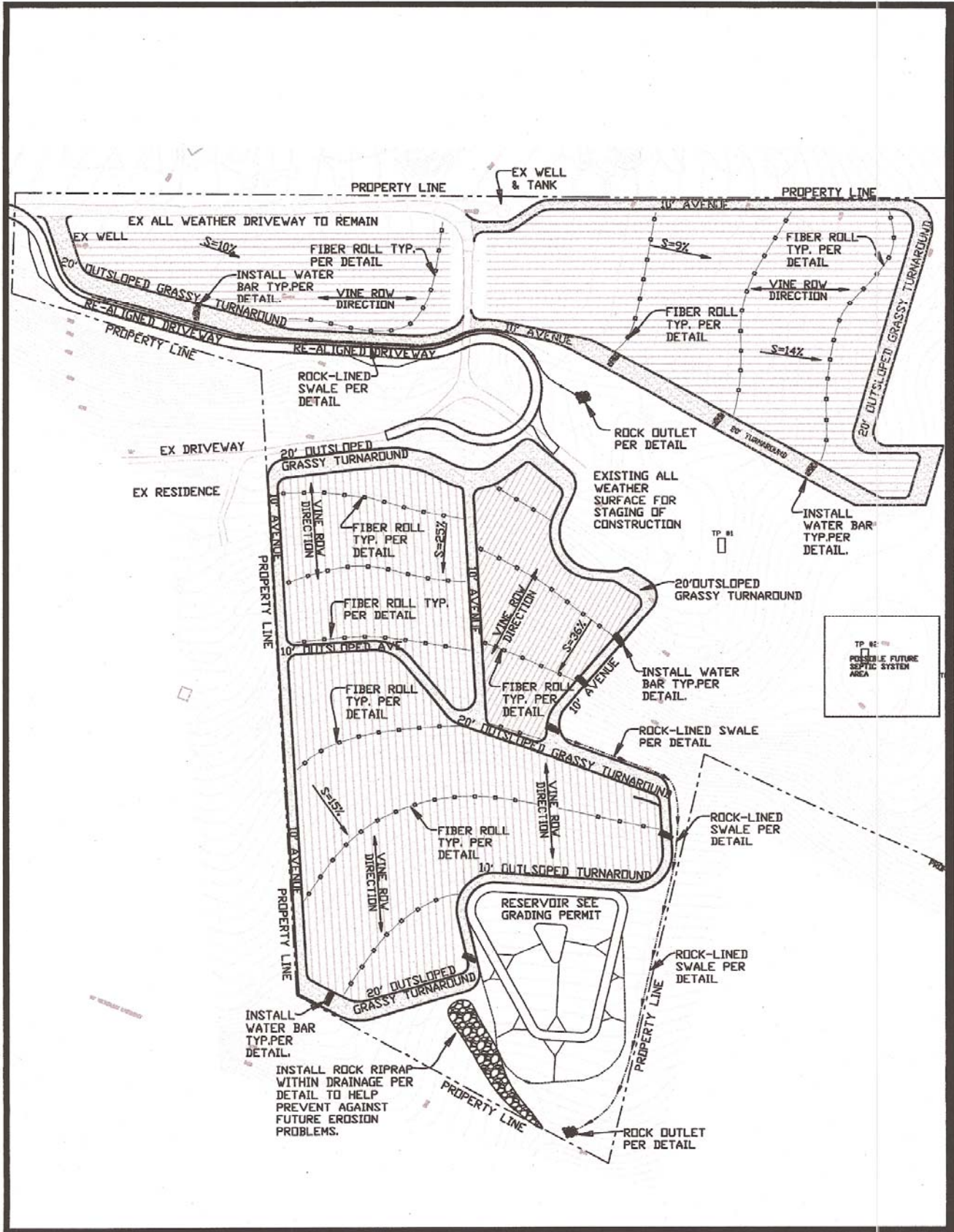

Example Vineyard Layout Near Stream

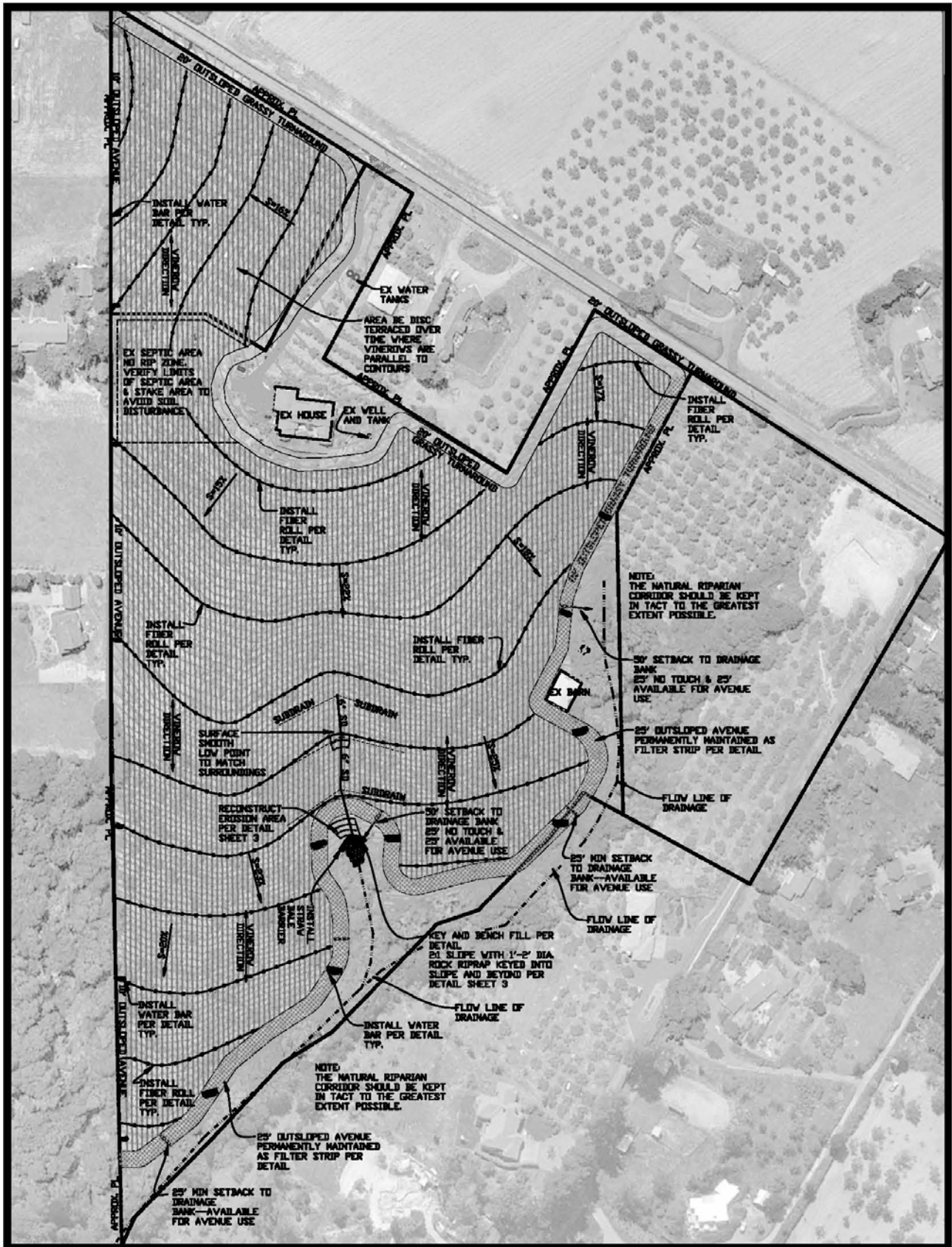

CHAPTER TWO

Roads

Fine sediments eroding from roads are a major source of sediment to streams in Sonoma County and throughout Northern California. Whether it is surface runoff or concentrated storm runoff, sediment and other pollutants are reaching streams and harming our natural resources.



Good planning, proper location and the use of progressive construction practices result in low maintenance, low impact roads.

Removing existing access roads from within the riparian zone will reduce fine sediment inputs, greatly improving spawning and rearing habitats for salmonids and eliminate the influence of the road on the stream system.

Environmental Concerns

Fine sediment delivered from roads to streams reduces the flow of oxygenated water to embryos, limits invertebrate prey, fills in pools used for rearing, and cements spawning gravels, reducing the area available for adult salmonids to successfully spawn.

If roads are built too close to a stream, the result is often that streams are armored and straightened to protect the adjacent road. Simplified channels provide less cover and rearing habitat for salmonids. Furthermore, roads interrupt the functions of riparian zones in providing bank stability, filtering sediment and pollutants, and providing shade, large woody debris, and invertebrates to streams.

Improperly sized or designed culverts are a common barrier to fish passage in Northern California stream systems.

Site Evaluation

Use a map or aerial photo to view the location of the road system, including abandoned and unused roads and identify all potential sources of sediment to the stream. Identify stream crossings and the type and size of culverts. Examine the downstream side of stream crossings to see if there is erosion from concentrating flows or by directing flows into the streambank.

Best Management Practices for Agricultural Roads

1. Decommission or relocate existing roads away from the riparian zone whenever possible.
2. Weatherproof or harden daily traffic roads. Pave or chip seal before the rainy season to allow toxic compounds in the oils to solidify, degrade or volatilize from the road surface and not be delivered to waterways.
3. Establish a thick cover crop on temporary or seasonal ranch roads by October 15. Depending on traffic, this may require active seeding annually.
4. Use straw mulch during the rainy season in places where cover crops are sparse. Monitor and augment straw treatments as necessary.
5. Blade existing roads in dry weather when possible, but while moisture is still present in soil and aggregate to minimize dust and maximize compaction to prevent road fines from being discharged from the road surface.
6. Do not sidecast the bladed material to areas where the material can enter the stream directly or indirectly as sediment. Sidecast material can indirectly enter the stream when placed in a position where rain or road runoff can later deliver it to a channel that connects with the stream.
7. Out-slope roads wherever possible to prevent the concentration of flow within the ditch, to promote even draining of the road surface and to minimize disruption of the natural sheet flow pattern off the hill slope to the stream.
8. If unable to eliminate in-board ditches, crowning the road can remove half the road surface drainage from the ditch.
9. Use water bars and rolling dips to break-up slope length, diverting water to well-vegetated areas.
10. Maintain in-board ditches and line them, if needed, with geotextile fabric or rock.
11. Remove stream crossings wherever possible.
12. Replace culverts, fords, or Humboldt crossings with single span bridges where possible
13. Ensure that all stream crossings meet National Marine Fisheries Service and California Department of Fish & Game guidelines for fish passage.
14. Design culverts to pass 100-year flow.
15. Check culverts periodically during the rainy season to ensure that they are not plugged with debris.
16. Minimize erosion downstream of culverts by using energy dissipaters.
17. Monitor energy dissipaters to make sure that they do not wash away or shift.

18. Maintain culverts at the level and gradient of the stream bed. In non-fish bearing streams, with "shotgun" culverts, use pipe extenders (e.g., elephant trunks) to bring the discharge down to the level and gradient of the stream.

Example Outsloped Road

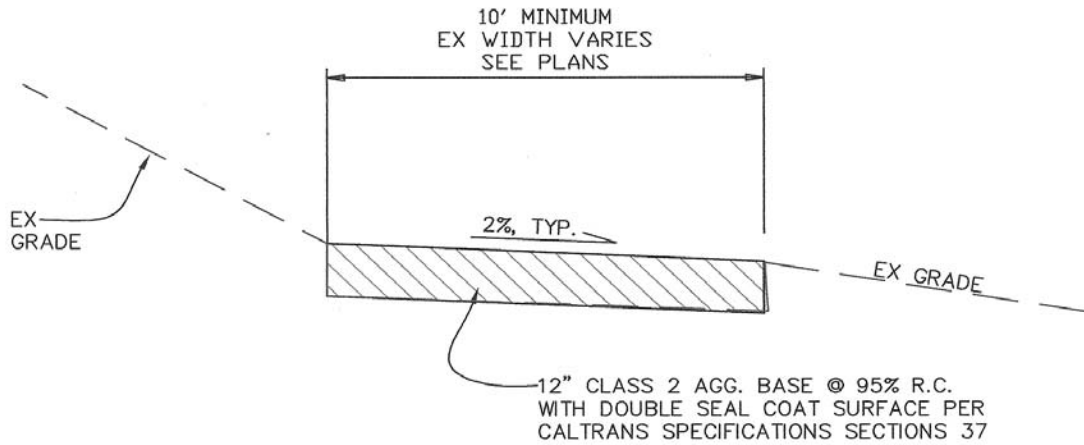

OUTSLOPED ROAD SECTION

N.T.S.

Example Insloped Road

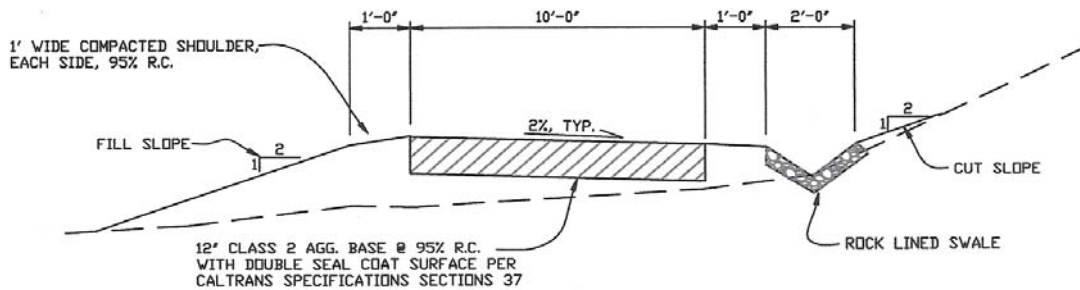

NOTES:

1. REMOVE ALL WEAK SOILS AS DETERMINED BY THE GEOTECHNICAL ENGINEER IN THE FIELD DURING CONSTRUCTION.
2. THE SURFACE EXPOSED BY REMOVAL OF WEAK SOILS SHALL BE SCARIFIED TO A DEPTH OF 8", UNIFORMLY MOISTURE-CONDITIONED TO WITHIN 2% OPTIMUM MOISTURE CONTENT, AND COMPACTED TO AT LEAST 95% R.C.
3. FOR FILL SECTIONS APPROVED, SELECT FILL SHALL THEN BE SPREAD IN LOOSE, 8-INCH THICK LIFTS, UNIFORMLY MOISTURE CONDITIONED TO WITHIN 2% OF OPTIMUM MOISTURE CONTENT, AND COMPACTED TO AT LEAST 90% R.C..
4. ALL EXPOSED SOIL SHALL BE PROTECTED FROM EROSION PER EROSION CONTROL NOTES

INSLOPED ROAD SECTION TYP.

NO SCALE

CHAPTER THREE

Cover Crops, Tillage Practices and Erosion Control

Planting cover crops is the most cost effective method to reduce the introduction of sediment, nutrients, and pesticides to the stream channel through overland flow.

In addition to their ability to prevent sheet erosion, cover crops can serve many agronomic purposes such as improving tilth, fixing nitrogen in the soil, and providing habitat for beneficial insects.



Environmental Concerns

Surface runoff can carry sediment, nutrients, and pesticides directly to a stream, where they affect salmonids and their habitat.

Site Evaluation

Inventory all areas that have rilling and eroded channels. Also, note areas that have sparse natural vegetation or areas where the cover crop has not taken. These areas may need some soil amendments or may need to be reseeded with a different seed mix

Best Management Practices

1. Establish thick cover crops by October 15 and maintain them throughout the rainy season (until April 15).
2. Use straw mulch (2 tons/acre) in areas where cover crops are planted late in the fall or if rain is likely after the cover crop has been tilled and there is no perimeter erosion control.
3. Whenever possible, avoid tilling early in the spring or late in the fall. Leave filter strip areas or other perimeter erosion control in place if the vineyard rows are tilled early.
4. Minimize tillage practices, especially if slopes are greater than nominal (>5-10%) or if soils are highly erodible.
5. Filter strip areas or other perimeter erosion control should be left in place if the vineyard/orchard rows are tilled early.
6. Do not till turn-around areas except for the infrequent need to reduce compaction. In this case, promptly cover the soil with straw and replant with a cover crop before the rainy season.

7. If you till regularly, use sedimentation basins or vegetated filter strips to filter sediment before it reaches the stream.
8. Avoid bringing equipment into the vineyard/orchard during the wet season. Close seasonal roads to traffic and maintain permanent roads to prevent erosion.
9. Keep on site extra erosion control materials such as straw bales or wattles, gravel or geotextile fabric and train vineyard crews in their proper installation.
10. Check the site after each rainfall event.

Cover Crops



Protecting bare soil surfaces is one of the best ways to prevent soil loss. Grasses, depending on the type, provide short-term soil stabilization for disturbed areas during construction of your project and can serve as long-term permanent soil stabilization for disturbed areas. There are many different seed mixtures you can choose from. Here are some key things to consider when choosing and planting a cover crop:

- Most important, be sure that your seed mixture provides overstory (tall fast growing plants like rye, grass, or barley) and understory (low growing broadleaf plants like clover) protection. For example, a mixture of oats and barley will only provide overstory protection and will only be slightly more effective than if you did nothing. The raindrops can still fall down between the tall plant stalks and dislodge soil particles. If you mix in some clover and brando brome, you will get understory protection and the soil will have better protection.
- The amount of seed you will need depends on the mix you choose. It can range from 30 lbs per acre for a more permanent type of cover crop to 90 lbs per acre for a quick erosion control soil builder mix. Your seed company will be able to help you determine what mix is best for your project and give you the recommended seed rate.
- Broadcast your seed in the fall. In order to have adequate protection by the start of the rainy season (October 15), the seed should be planted by mid-September. Initial irrigation will be required for most grasses with follow-up irrigation and fertilization. The cover crop should look like a lawn by October 15 (for new plantings and November 15 for replants) in order to provide adequate protection for the soil during the first heavy rains. If you cannot plant by mid-September and irrigate the seed, then you may plant your seed in October **and** cover it with straw mulch applied at the rate of two tons per acre.

The following section will give you guidelines on seed mixes for cover crops and application rates.

Example Cover Crop Seed Mix



**Hillside- Shallow Soils
"Erosion Control"**

"Zorro" annual fescue	40%
"Blando" brome	27%
"Hykon" rose clover	23%
(seeding rate: 25lbs. per acre)	

**Hillside Soils
-Frequent Mowing-**

"Zorro" annual fescue	40%
Subterranean clover	35%
"Hykon" rose clover	25%
(seeding rate: 30 lbs. per acre)	

**Hillside Quick Erosion Control
"Soil Builder"**

Red Oats	65%
Crimson clover	13%
Austrian winter pea	22%
(seeding rate: 90 lbs. per acre)	

**Quick Erosion Control
-Cold Soils-**

Cereal rye	83%
Crimson clover	17%
(seeding rate: 90 lbs. per acre)	

**Vineyard Terrace
"Slope Stabilizer"**

"Blando" brome	45%
"Molate" red fescue	55%
(seeding rate: 25 lbs. per acre)	

**Native, No-till Blend
(Mature vineyards)**

California meadow barley	36%
"Molate" red fescue	38%
California brome	26%
(seeding rate: 39 lbs. per acre)	

Example Cover Crop Seed Mix



**Native, No till Blend
"Low growing"**

Idaho fescue	50%
"Molate" red fescue	50%

(seeding rate: 30 lbs. per acre)

**High Altitude
"Mountain Turf"**

Perennial ryegrass	35%
Creeping red fescue	35%
"Covar" sheep fescue	30%

(seeding rate: 32 lbs. per acre)

Grassed Waterways**

Meadow Barley	41%
California brome	33%
"Blando" brome	26%

(seeding rate: 39 lbs. per acre)

** straw mulch and irrigate to germinate before fall rains.

**Emergency Winter Mix
"Quick Cover"**

Common barley	85%
Annual ryegrass	15%

(seeding rate: 100 lbs. per acre)

**Heavy Use Areas
-Vineyard Headlands-**

Bluebunch wildrye	40%
Cal.meadow barley	27%
California brome	33%

(seeding rate: 45 lbs. per acre)

"Showboat"

Crimson clover	44%
"Hykon rose clover	44%
Wildflower blend-	12%
Yarrow	
Calif. Poppy	
Paper poppy	
Tidy tips	

(seeding rate: 27 lbs. per acre)

Straw Mulch



The most effective erosion control practice (both in terms of protection and cost) is the use of cover crop and straw mulch. Straw provides a cushion between the disturbed soil and the velocity of the raindrop. It's the best insurance for **protection** from the early rains if you cannot plant your cover crop in mid-September and irrigate it.

- In order for straw to be effective, you must apply it at the rate of two tons per acre (about 42 bales per acre). You should not be able to see any soil once the straw is applied.
- Rice straw is the cleanest straw in terms of other weed seeds, but it is a coarse straw and therefore takes longer to degrade. Any straw or grass hay will work provided it's applied at the rate of two tons per acre.
- If you are in an area that has high winds in the fall you must anchor your straw into the ground. You can do this by tracking it in (see example) or by crimping it. Otherwise, be prepared to replace the straw that gets blown away.
- Keep extra straw bales stored for emergency erosion control repairs. If you have an area that starts to gully you can stuff the gully with straw. You can also build emergency dikes to control drainage (see sediment barrier example).

Example Tracking In Straw Mulch

Notes:

1. Roughen slope with bulldozer.
2. Broadcast seed and fertilizer.
3. Spread straw mulch 3" thick (2 tons/acre).
4. Punch straw mulch into slope by running bulldozer up and down the slope.
5. Tracking with machinery on sandy soil provides roughening without undue compaction.

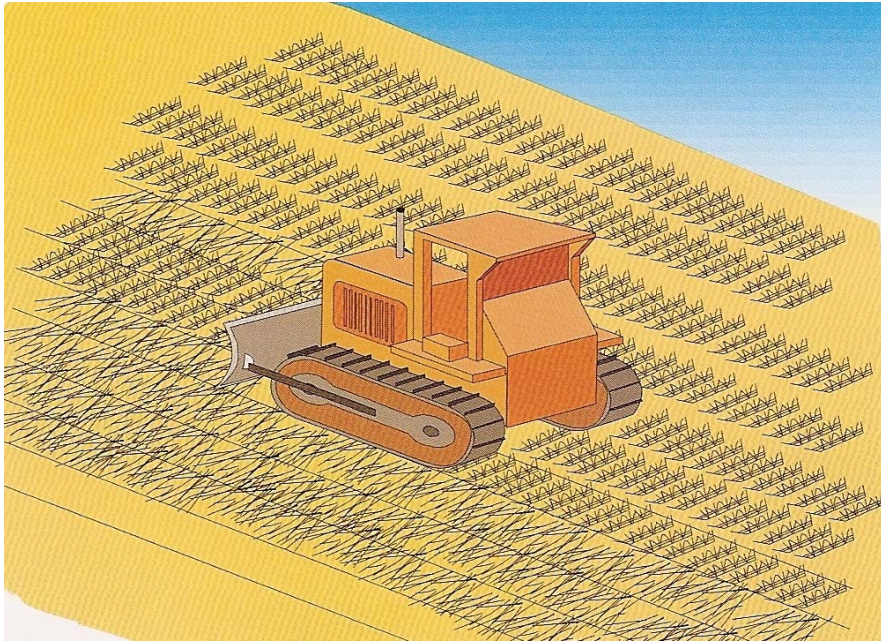

Example Straw Bale Sediment Barrier

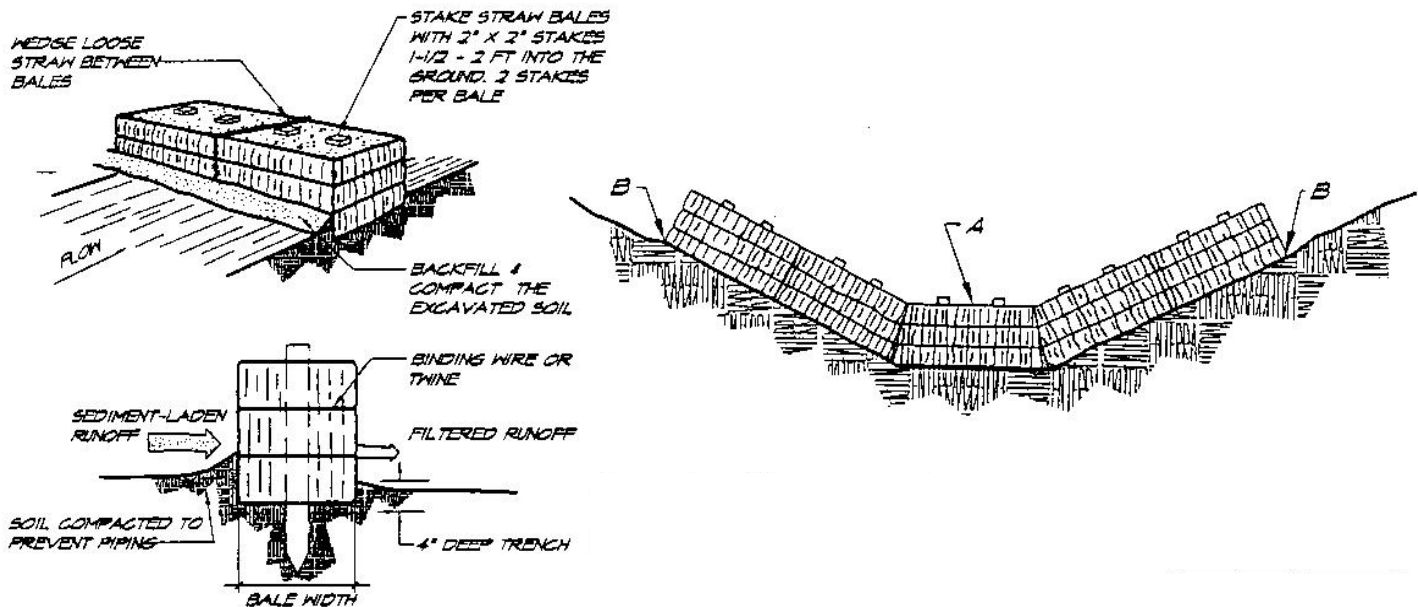

Straw Wattles



Straw wattles or fiber rolls are designed to slow down runoff, filter and trap sediment before the runoff gets into watercourses. Straw wattles are porous and allow water to filter through fibers and trap sediment. They also slow down runoff thereby reducing sheet and rill erosion.

- Straw wattles are effective on slopes to shorten the slope length. They are designed for short slopes or slopes flatter than 3:1 and low surface flows not to exceed 1 c.f.s. for small areas.
- Straw wattles can also be used along stream banks for extra protection.
- They come in several sizes ranging from 8 to 20 inches in diameter.
- It's very important that straw wattles are installed properly. If they're not installed properly, they will not work. Straw wattles must be installed on contour. You may need to have a surveyor help you to be sure you find the contours of your area.
- A good rule of thumb for vertical spacing is: 3:1 slopes = 30 feet apart, 4:1 slopes = 40 feet apart, or as the project engineer dictates.
- Cover Crop should be seeded prior to installation. You will then need to dig a concave key trench 2 to 4 inches deep along the contour. Place the roll in the trench and stake (see example). You must backfill the trench on the uphill or flow side of the roll to prevent water from undercutting the roll. When more than one fiber roll is placed in a row, the roll should be abutted securely to one another with stakes to provide a tight joint. **Do not overlap the joint.**
- After your fiber rolls are in place, the straw mulch can be applied at the rate of 2 tons per acre. Do not drive over the straw wattles.

Example Straw Wattle

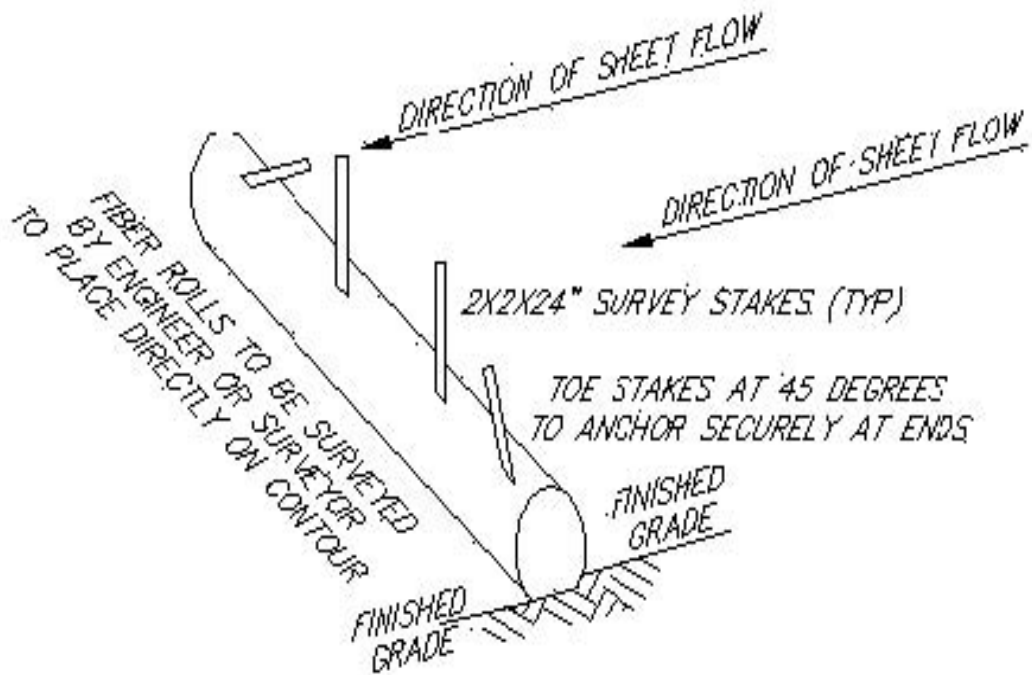
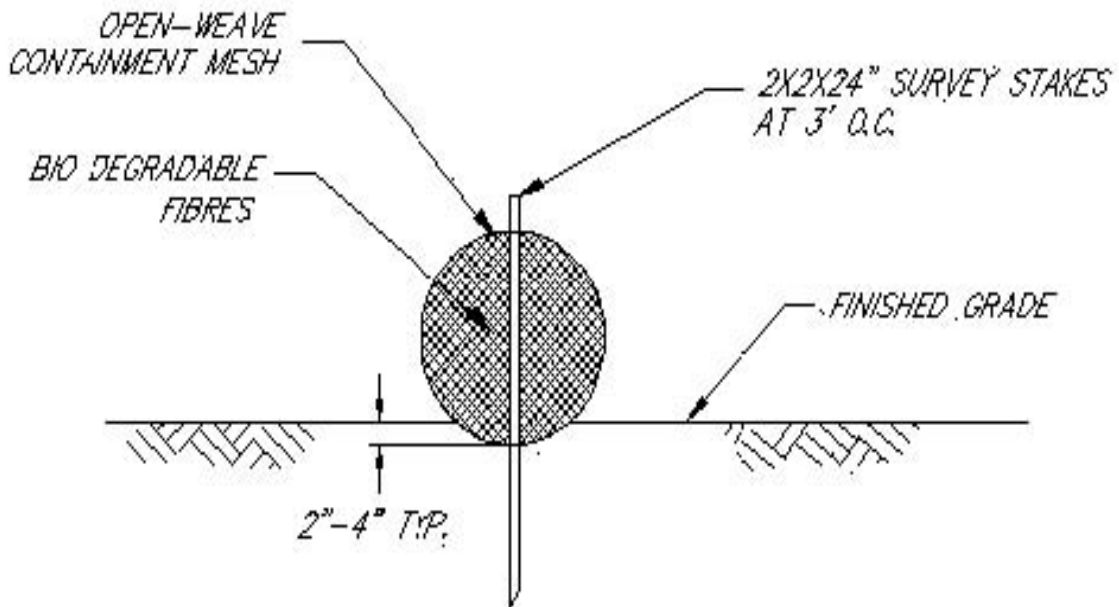

CHAPTER FOUR

Drainage

Drainage systems should be designed and maintained to maximize infiltration and minimize sediment delivery to stream by dissipating flow energy, spreading flow, and encouraging infiltration. Drainage systems need to be periodically monitored and maintained to address erosion issues before they cause severe erosion or require costly repairs. It is better to have numerous discharge points in order to avoid the scouring effects of concentrated flow. Drainage systems can, and in some cases should, be designed to discharge into an off-channel water supply reservoir rather than directly to streams.



Drainage systems in new vineyards/orchards or replants in Sonoma County are required by county ordinance to be designed for at least a 25-year storm. They can require design or design approval by an approved civil engineer and should incorporate natural features of the landscape (such as swales) into the drainage system.

Environmental Concerns

Excess fine sediment suffocates developing salmonid embryos, reduces the availability of invertebrate prey to juvenile salmonids, reduces the depth of pools used for rearing, and embeds spawning gravels. Drainage systems should be designed to allow for infiltration and filtration of fine sediment to maintain quality instream habitat conditions for salmon and steelhead.

Drainage systems that rapidly transport rainfall to a stream increase peak flows and decrease groundwater recharge. Changing the natural hydrograph can act as a barrier for fish migrating upstream as adults or downstream as smolts.

Site Evaluation

Inventory all streams, natural drainage swales, wetlands and ponds, existing drainage structures such as culverts under roads, drainage ditches, inlets, outfalls, and sediment ponds.

Evaluate any existing erosion problems and unstable areas.

Best Management Practices

1. In accordance with the Sonoma County Grading Drainage and Vineyard and Orchard Site Development Ordinance, design drainage system to handle a 25-year storm; obtain designs or design approval from a civil engineer as required.
2. Incorporate natural drainage features into the vineyard/orchard plan to maintain natural sheet flow whenever possible. Consider using vegetated swales as an option to drain pipe whenever possible.
3. Monitor vegetated swales for signs of instability, especially in vineyards/orchards with more than minimal slopes and where water has been concentrated into the swale. Consider reinforcing swales with geotextile fabric or grade control structures for additional stability.
4. Spread and slow flows by incorporating the following BMP options into the drainage system:
 - Vegetated filter strips
 - Rocked energy dissipaters
 - Vegetated check dams or straw bale sediment barriers along ditches or swales
 - Daylight underground outlets to rocked ditches or vegetated swales
 - Sediment or infiltration basins
 - Straw wattles
5. Increase rainfall infiltration to recharge aquifers using the following BMP options:
 - Cover crops
 - Straw mulching
 - Detention ponds
 - Infiltration galleries.
6. Use equipment or specialty tires that minimize soil compaction.
7. Provide sediment collection features on all drop inlets.
8. Provide energy dissipaters for all pipe outfall areas.
9. Discharge drainage pipes upslope of riparian areas and stream banks.
10. Use trash racks or caps on drop inlets to prevent debris such as branches from entering the system.
11. Maintain capacity of sediment basins by removing sediments when dry and placing sediment in an area where it will not enter a stream. Design the release of water from sediment basins to mimic natural flow patterns while retaining the sediment in the pond.
12. Perform culvert and drop inlet cleaning on a regular basis, before the wet season begins (October 15) as well as during and after any large storm.
13. Check temporary erosion control measures and repair as needed during and after storms: Remove sediment as needed from silt fences, sandbags, straw wattles, and sediment traps. Permanent measures, such as seeding, planting, and rocking, are preferred once the source of any runoff problem is corrected.

Example of Vineyard Inlet With Sediment Trap

All drop inlets should have a sediment collection component. Surface water should be filtered in some way to allow the fines to settle out before the water enters the pipe. Existing drop inlets that do not have a sediment collection component can be easily modified by adding a corrugated plastic pipe collar around the existing pipe. The collection area (sump) must be a minimum of 6 inches deep.

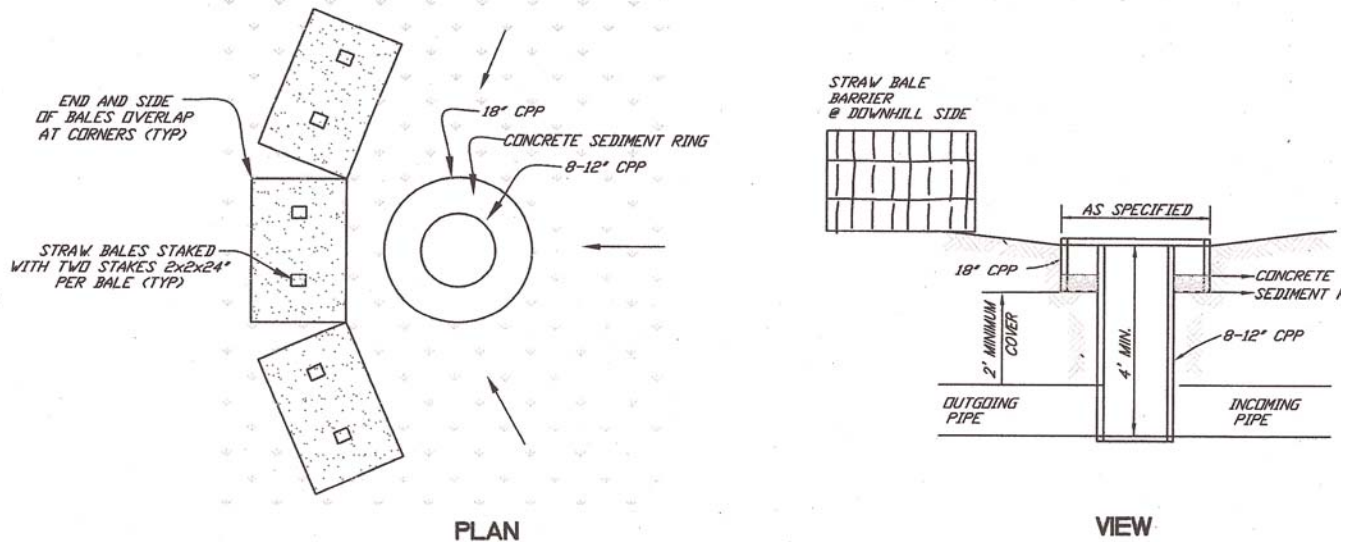

Example of Concrete Inlet With Sediment Trap

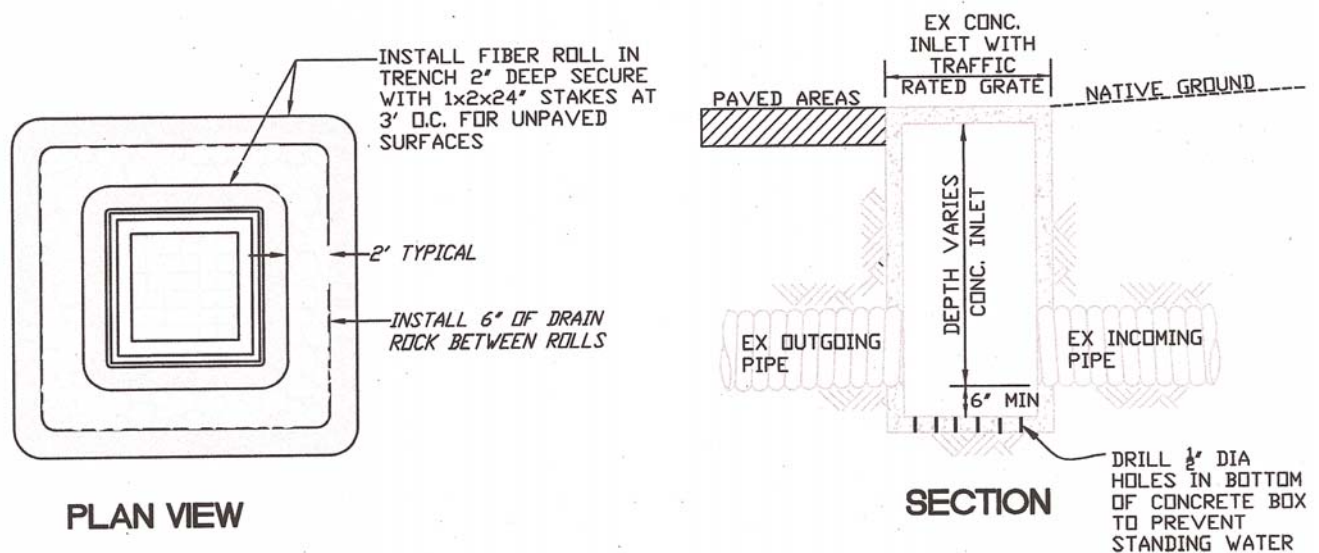

Example of Rock Outlet for Storm Drains

All pipe outfalls should have scour protection to minimize sediment delivery downstream. The size of the dissipater is dependent on the size of the pipe. Rock protection can be easily added to existing pipe outfalls. Do not outfall the pipe directly into a creek.

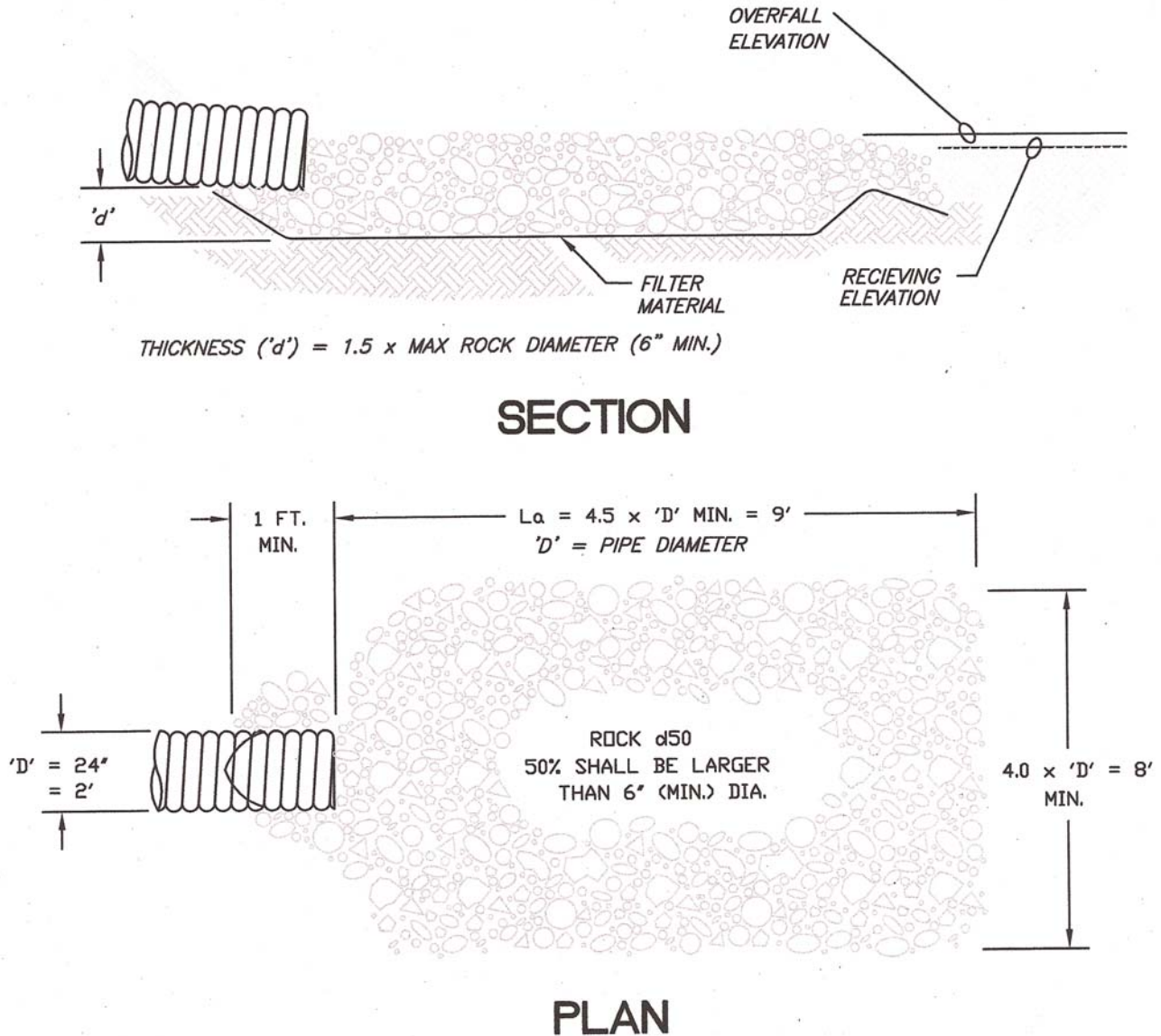

NOTES:

1. 'L_a' = LENGTH OF APRON. DISTANCE 'L_a' SHALL BE OF SUFFICIENT LENGTH TO DISSIPATE ENERGY.
2. APRON SHALL BE SET AT A ZERO GRADE AND ALIGNED STRAIGHT.
3. FILTER MATERIAL SHALL BE FILTER FABRIC OR 6" THICK (MIN.) GRADED GRAVEL LAYER.

Example of Rock Outlet for Swales

All swale outfalls should have scour protection to minimize sediment delivery downstream. Rock protection can be easily added to existing swales.

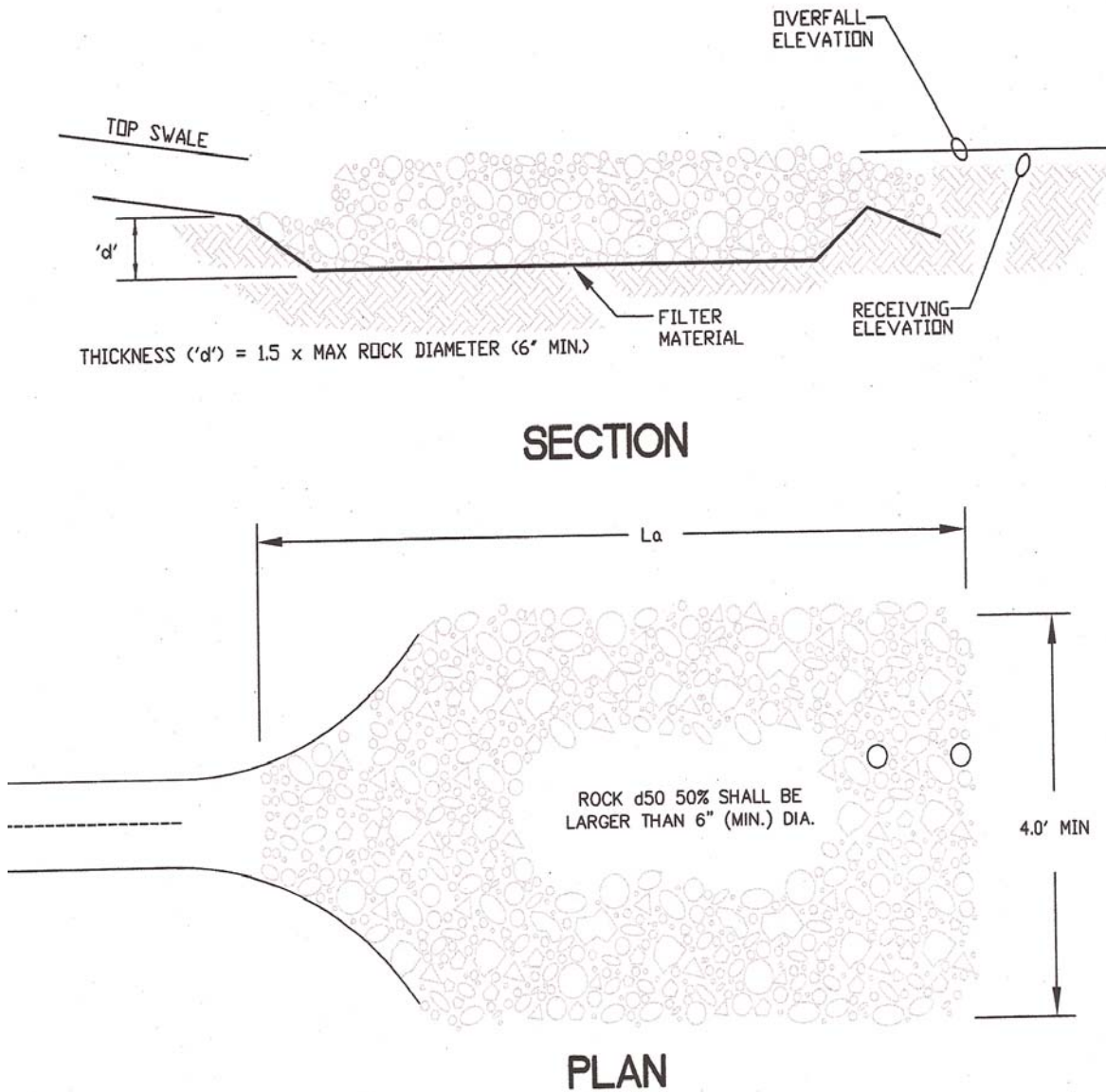

NOTES:

1. 'La' = LENGTH OF APRON. DISTANCE 'La' SHALL BE OF SUFFICIENT LENGTH TO DISSIPATE ENERGY.
2. APRON SHALL BE SET AT A ZERO GRADE AND ALIGNED STRAIGHT.
3. FILTER MATERIAL SHALL BE FILTER FABRIC OR 6" THICK (MIN.) GRADED GRAVEL LAYER.

Example Sediment Basin

Basins should be designed to drain within 72 hours following storms. The length of the basin should be more than twice the width of the basin determined by measuring the distance between the inlet and the outlet. All slopes should be protected with erosion control blankets.

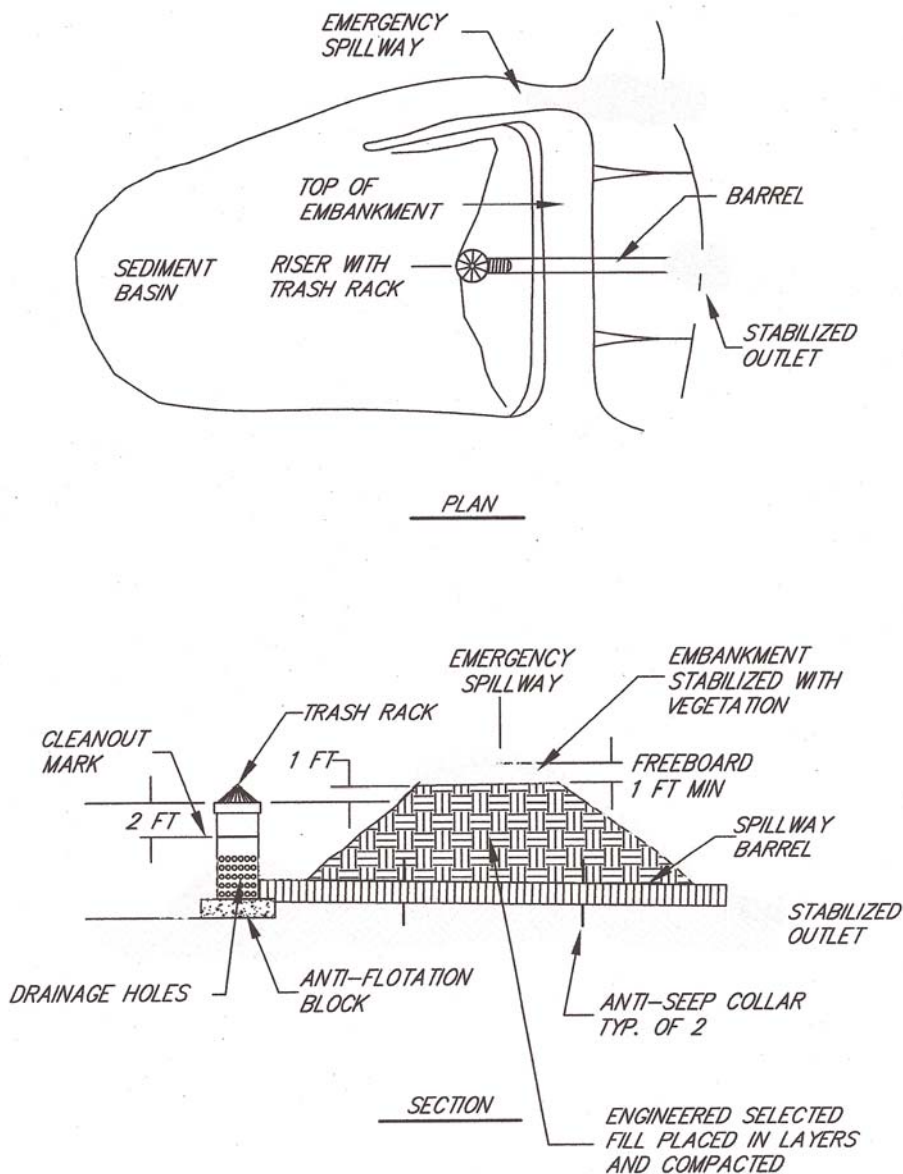

NOTES:

1. THE TEMPORARY SEDIMENT BASIN, DESIGNED BY A QUALIFIED PROFESSIONAL, IS REQUIRED FOR DISTURBED AREAS GREATER THAN 5 ACRES WITHIN A DRAINAGE AREA LESS THAN 100 ACRES.
2. THE SEDIMENT BASIN WILL BE REMOVED WITH- IN 3 YEARS.

Example Aq Road Water Bar

Water bars should be installed when the slope of the road or avenue exceeds 15%. Construct water bars not more than 100 feet apart or 50 feet apart for steeper slopes.

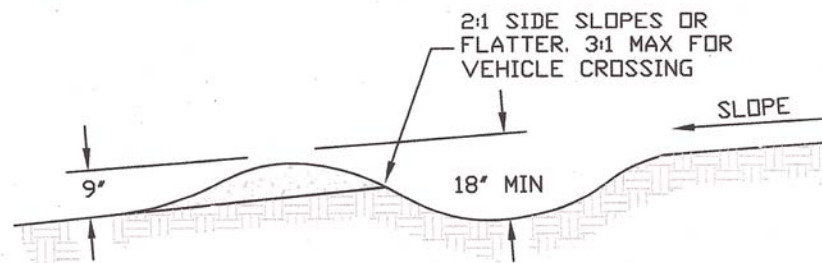
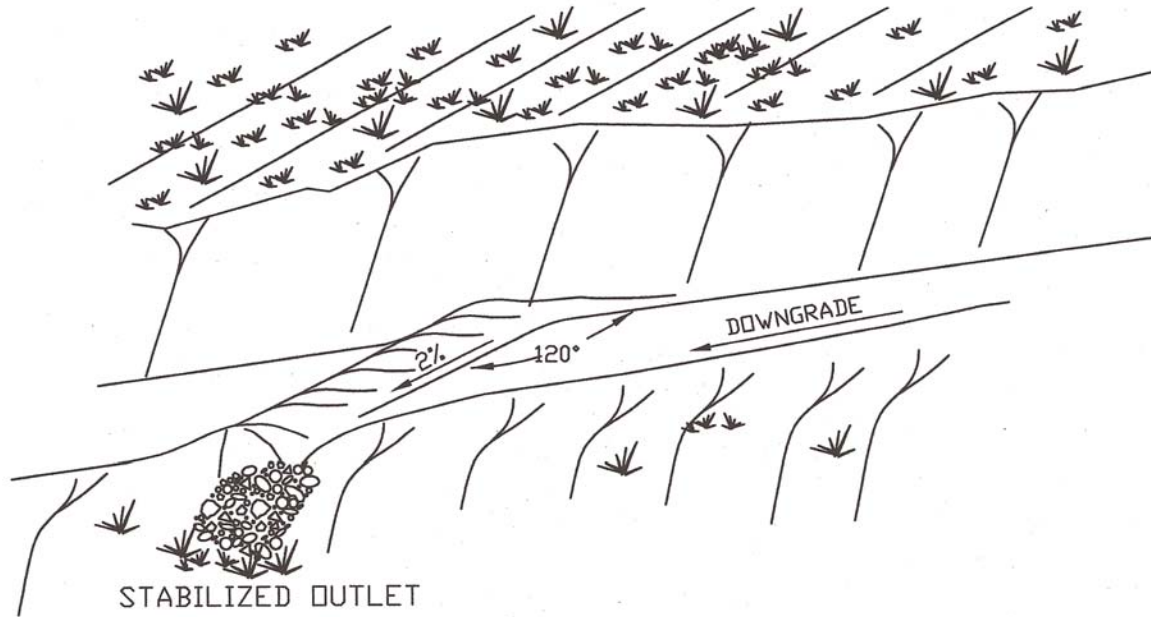

Example Temporary Drainage Swale

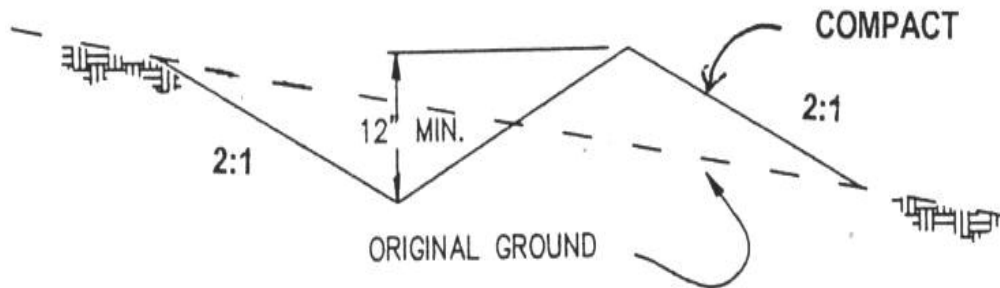

NOTES

1. Construct drainage swale on contour
2. Flowline slope should not exceed 4%.
3. Swale should not be longer than 150 feet.

CROSS SECTION

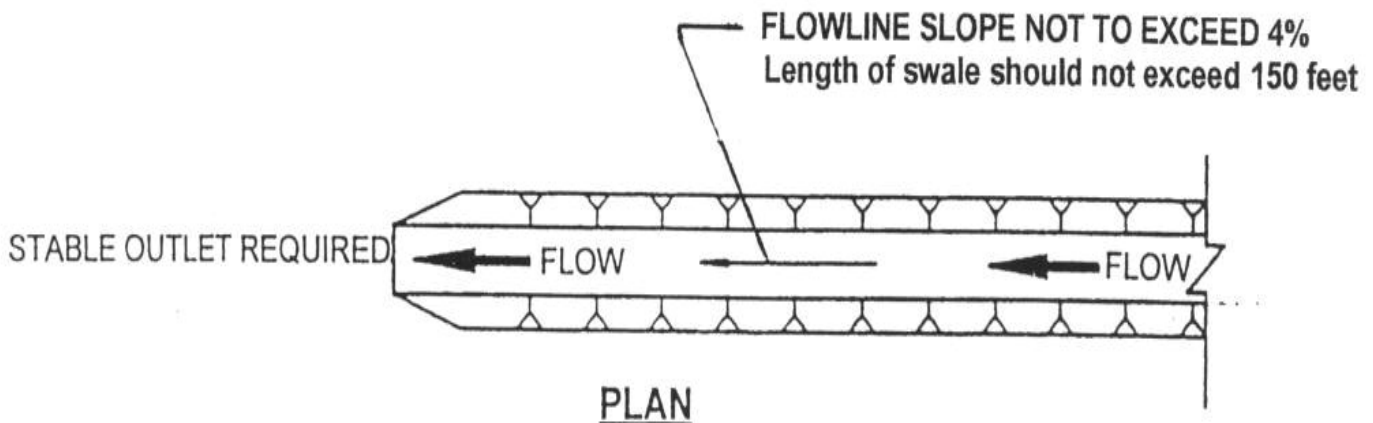

CHAPTER FIVE

Riparian Zones

Riparian zones provide and maintain many of the essential habitat features necessary to complete the salmonid life cycle such as erosion control, shade and temperature regulation, macroinvertebrate food supply, large woody debris supply, and filtration of sediments, nutrients, and pollutants.

Riparian vegetation also increases the water storage capacity of the soil, allowing for increased flow volumes within the streams during the warmer months.



Environmental Concerns

Bare stream banks are significantly more likely to erode than forested stream banks. Excessive bank erosion degrades salmonid habitat by filling pools, burying spawning gravels, and decreasing macroinvertebrate production.

Removal of riparian vegetation causes elevated stream temperatures which can create thermal migration barriers for migrating salmon, generate stressful rearing conditions, decrease oxygen solubility and encourage disease.

Loss of large woody debris alters natural geomorphic functions.

Loss of litterfall alters the food source for many aquatic macroinvertebrates which in turn are important salmonid food source.

Site Evaluation

Evaluate your riparian areas. Measure the smallest and largest portions of the existing riparian zone, as well as vegetation composition, the extent of stream shading, and the distance from the edge of the riparian corridor to the first row of vines/orchard. Note any previous land use practices, infrastructure, roads, or structure within the riparian zone.

Best Management Practices

1. Abide by the required stream, pond, and wetland setbacks as defined in the County's Grading, Drainage, Vineyard/Orchard Site Development Ordinance.
2. Maintain the existing riparian zone. A healthy riparian zone consists of trees, shrubs of different ages growing closest to the channel and a grassy zone closest to the vineyard/orchard operation.
3. Maintain existing riparian vegetation to provide at least 65% shading of streams less than 50 feet in wetted width.
4. Plant native species in riparian zones that are not presently forested. Irrigate for the first two or three years and protect from browsing. Once established, leave riparian zone in a natural state.
5. Replace existing all-weather access roads that are within the county required setback no touch areas with grassy avenues. If the road must be used as an all-weather access road, then move the road out of the setback area and replant the old roadbed with riparian vegetation and/or a filter strip.
6. Leave downed trees in the riparian corridor for recruitment as large woody debris, as long as it does not pose an immediate threat to infrastructure or property downstream.
7. Maintain grass buffers along natural streams and drainage channels with a defined bed and bank.
8. Cooperate in watershed-wide restoration projects that will help to improve riparian habitat.

Required Stream Setbacks (Sonoma County Grading, Drainage, Vineyard/Orchard Site Development Ordinance):

DETAILS: Existing riparian corridors should be maintained. The roots of the vegetation provide bank stability. Shade from trees and bushes keep water temperatures cool, which is important for sustaining aquatic species. Native grasses help filter sediment from surface runoff. However, if the existing vegetative cover is in poor condition the setback area may be improved with a vegetative filter strip for use as an agricultural avenue. The strip must be planted with a filter strip seed mix and maintained for the intended use.

Level I Projects and All Replants

(Setbacks apply to all new vineyards/orchards with a slope of 10% or less on highly erodible soils or 15% or less on non-highly erodible soils and all replant projects, unless stricter requirements are established in the general plan, local coastal program, and/or zoning code.)

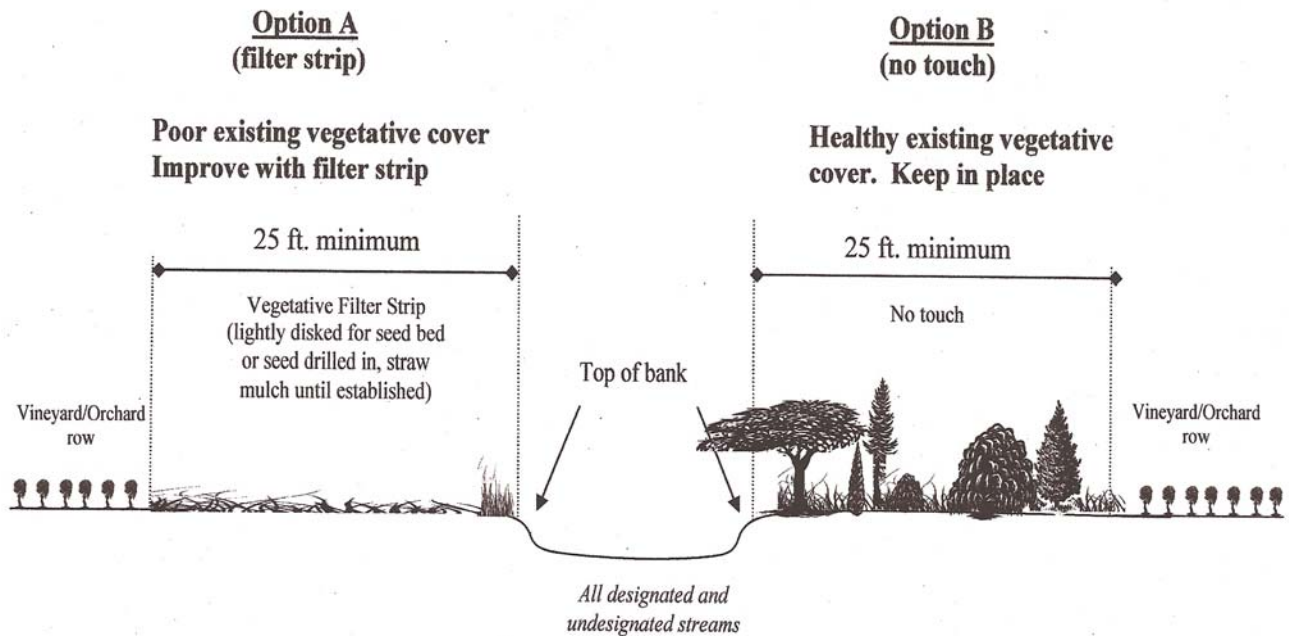

NOTE: Vegetative filter strips may be used as turnarounds or grassy avenues provided the filter strip is maintained for the intended use.

Level II Projects

(Setbacks apply to all new vineyards/orchards with a slope greater than 10% on highly erodible soils and greater than 15% on non-highly erodible soils, unless stricter requirements are established in the general plan, local coastal plan, and/or zoning code.)

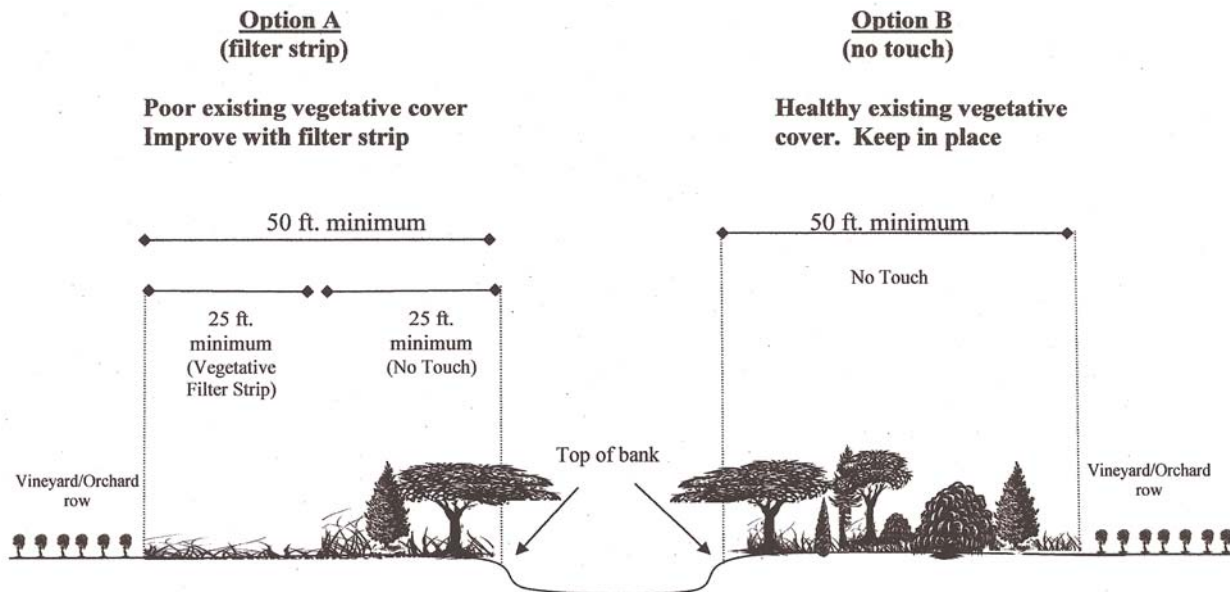

All Designated Streams

Undesignated streams require a 25 ft. (min.) setback

NOTE: Vegetative filter strips may be used as turnarounds or grassy avenues provided the filter strip is maintained for the intended use.

Example Vineyard Setback/Filter Strip

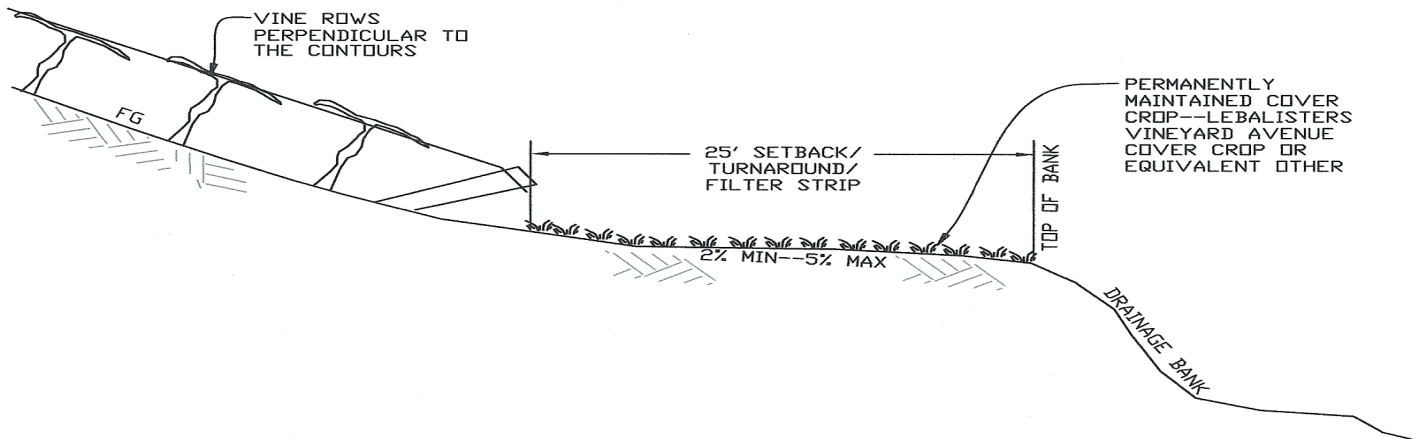

25' SETBACK/TURNAROUND/FILTER STRIP

NO SCALE

Required Wetland and Pond Setbacks

(Sonoma County Grading, Drainage, Vineyard/Orchard Site Development Ordinance)

DETAILS: Existing wetland and pond vegetation should be maintained. The roots of the vegetation provide bank stability. Shade from trees and bushes keep water temperatures cool, which is important for sustaining aquatic species. Native grasses help filter sediment from surface runoff. However, if the existing vegetative cover is in poor condition, the setback area may be improved with a vegetative filter strip for use as an agricultural road. The strip must be planted with a filter strip seed mix and maintained for the intended use.

(Setbacks apply to all new vineyards/orchards, unless stricter requirements are established in the general plan, local coastal plan, and/or zoning plan.)

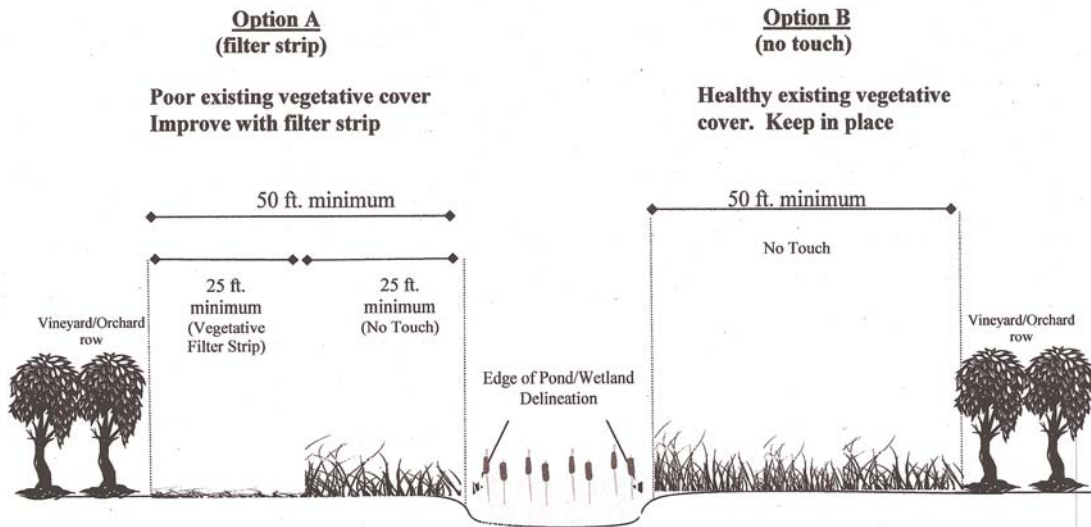

NOTE: Vegetative filter strips may be used as turnarounds or grassy avenues provided the filter strip is maintained for the intended use.



Sonoma County Agricultural Commissioner's Office
133 Aviation Blvd., Ste. 110
Santa Rosa, CA 95403
Phone: (707) 565-2371
Fax: (707) 565-3850